





PARTS IDENTIFICATION

A. SERVER

1 SET



HARDWARE IDENTIFICATION

1.		SHORT SCREW M4 X 15mm	2 PCS.
2.		LONG SCREW M4 X 35mm	2 PCS.
3.		CABLE TIE	1 PC.
4.		BRACKET	2 PCS.

This tip restraint must be attached to a wall stud using long screw enclosed.

STEP 1

Attach a bracket securely to the back top rail of the server using short screw provided, through the smaller hole.

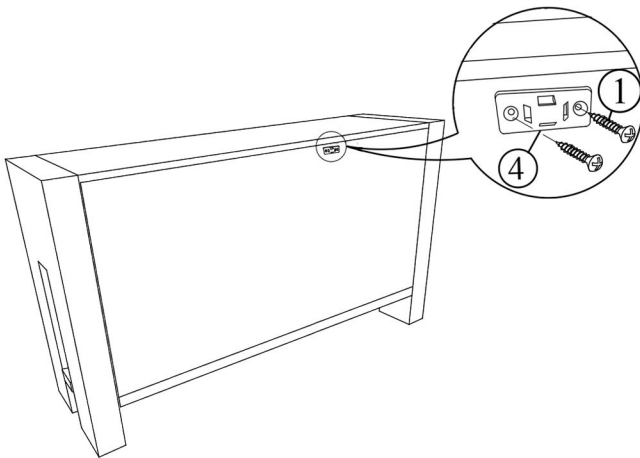

STEP 2

Locate the other bracket on the wall over a wall stud and two inches below the mounting bracket secured to the back of server. Attached to the wall stud using the long screw provided, through the smaller hole.

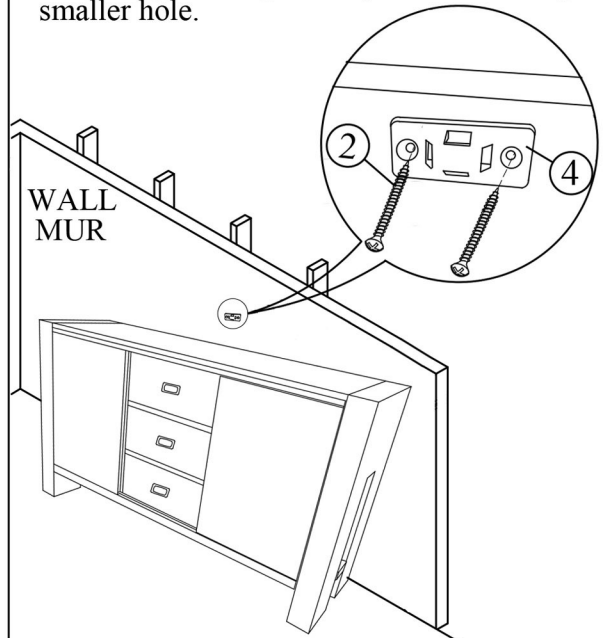

STEP 3

Place the server into position so both mounting brackets are vertically in line. Lace the end of the restraint strap through the larger hole in each mounting bracket. Bring both ends together and slide the flat end through the locking end and draw it through until all slack is removed. Confirm that the strap is securely laced and locked.

