

ASSEMBLY INSTRUCTION

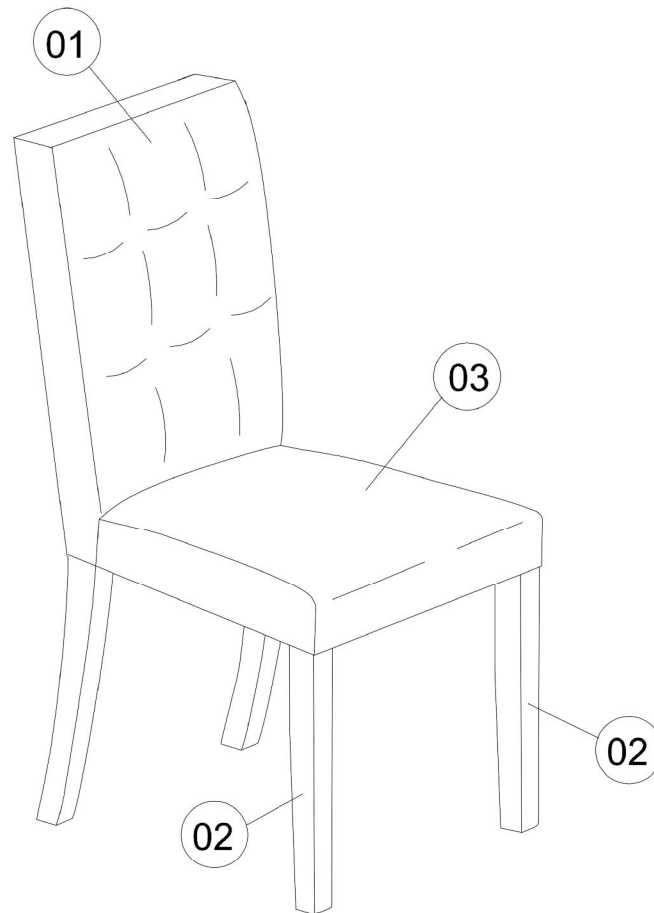





ITEM DESCRIPTION : 5039S SIDE CHAIR



PART LIST FOR 1PC CHAIR

NO	DESCRIPTION	QTY
1	CHAIR BACK	1 PC
2	CHAIR LEG (L & R)	2 PCS
3	CHAIR SEAT	1 PC

HARDWARE LIST FOR 1PC CHAIR

NO	DESCRIPTION	QTY
A	JCBC BOLT M6 x 80MM 	4
B	JCBC BOLT M6 x 60MM 	4
C	FLAT WASHER M6 X 19MM 	9
D	SPRING WASHER M6 X 12.5MM 	9
E	SHORT ALLEN KEY M4 	1
F	JCBC BOLT M6 x 45MM 	1

- 1** Remove the black woven on bottom of the box seat.

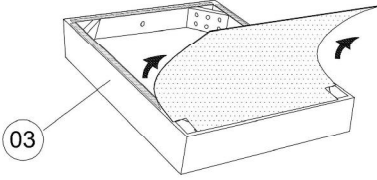

- 2** Insert the chair legs to the seat frame, tighten with bolts and washers.

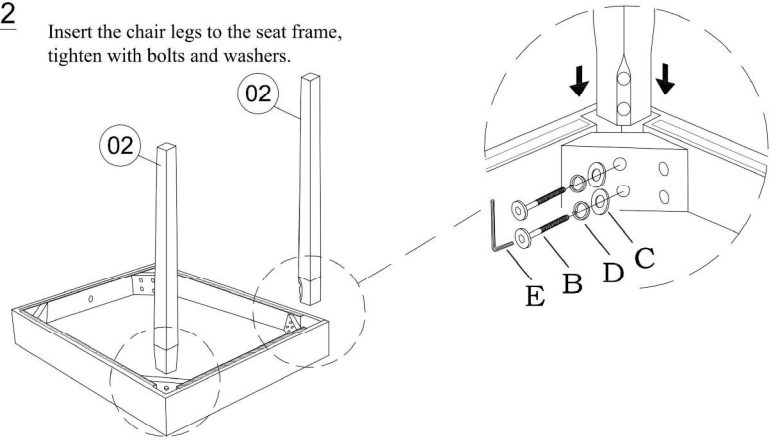

- 3** Insert the bolts and washers to the pre-drilled holes as shown in drawing, do not tighten it.

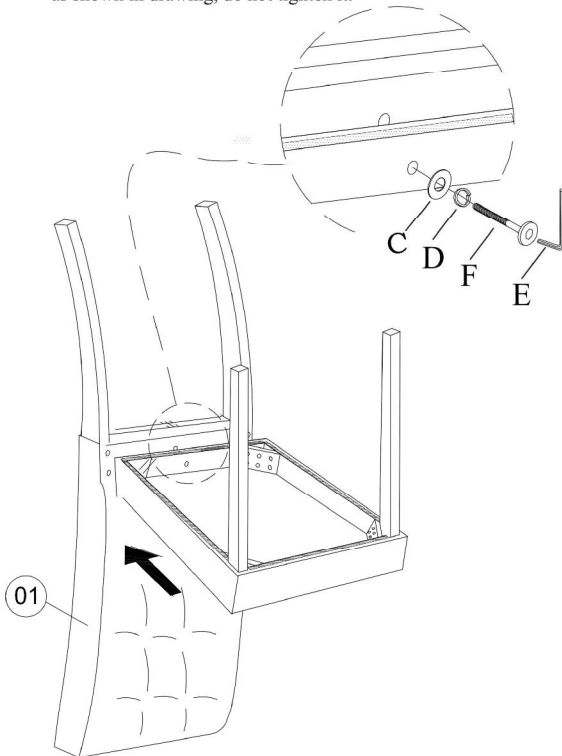

- 4**

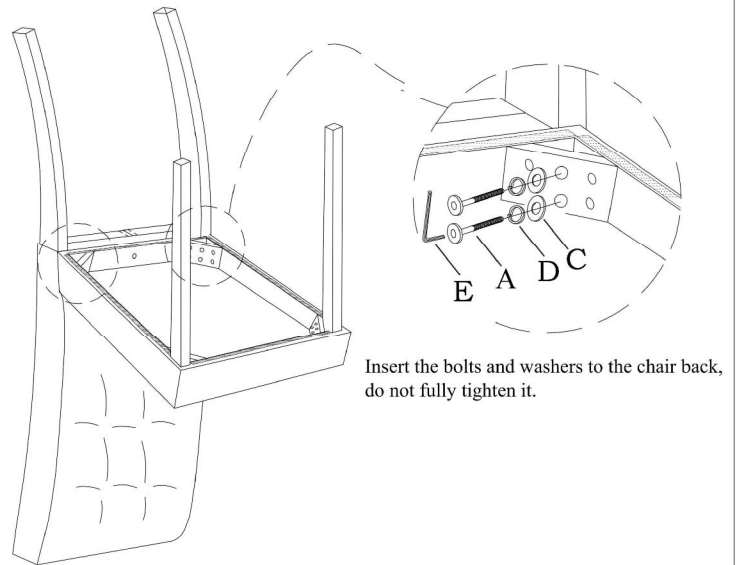

- 5** Upright the chair and tighten all the screws properly, make sure the chair is stable.

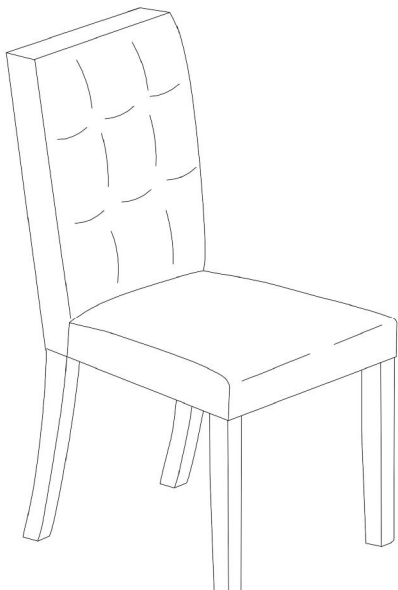

- 6** Cover back the black woven to the bottom of the box seat.

