

ASSEMBLY INSTRUCTION INSTRUCTIONS D'ASSEMBLAGE

Item : 5603WW-24

Description : COUNTER HEIGHT STOOL

Thank you for purchasing the product. Please take time to read and follow the instruction below. Check that you have all parts hardware before assembly. Parts apparently missing are often found in the packing materials. If you do not have all the parts listed, have your dealer contact us they will be sent to you immediately.

Merci d'avoir achete ce produit. veuillez lire et suivre les instructions ci-dessous. Verifiez avant le montage que vous avez toutes les pieces et fixations. Les pieces qui semblent manquer se trouvent souvent dans les materiaux d emballage. Si vous n avez pas toutes les pieces de la liste, demandez a votre detailliant ety nous vous les enverrons immediatement.

⚠ It is recommended to install protective pads under all legs and supports to avoid damage or scratches when placing furniture on a wood floor or other hard surface, and to limit indentation and prevent discoloration if placing on carpet.

⚠ Il est recommande de placer des coussins protecteurs sous tous les pieds et toutes les bases des meubles pour eviterd endommager ou d egrantigner les planchers en bois ou autres surfaces dures, et pour limiter l'empreinte et empecher la decolorations quand les meubles resopent sur la moquette.

PARTS LIST (FOR 2 CHAIR)		
NO	DESCRIPTION	QTY/PCS
1.	CUSHION SEAT	2 PCS
2.	STOOL LEG (MARKED 'L')	4 PCS
3.	STOOL LEG (MARKED 'R')	4 PCS
4.	LONG STRETCHER (MARKED 'FRONT')	4 PCS
5.	SHORT STRETCHER	4 PCS

HARDWARE LIST (FOR 2 CHAIR)		
NO	DESCRIPTION	QTY/PCS
A.	JCBC SCREW M6 X 60MM	16 PCS
B.	SPRING WASHER 5/16"	16 PCS
C.	FLAT WASHER 5/16" X 16MM	16 PCS
F.	CSK SCREW M4 X 38MM	16 PCS
D.	ALLEN KEY M4 (SHORT)	1 PC

NOTE : YOU WILL ALSO NEED A PHILLIP SCREWDRIVER (NOT PROVIDED) / VOUS AUREZ ÉGALAMENT BESOIN D'UN TOURNEVIS PHILIP (NON FOURNI)

STEP 1

Place the Cushion Seat (1) on a piece of cloth to prevent finish from scratching. Attached Stool Leg (2) & (3) to the corner block of Cushion Seat (1). Insert Long Stretcher (4) in between Stool Leg (2) & (3). Tighten the Stool Leg (2) & (3) with Flat Washer (C), Spring Washer (B) and JCBC Bolt (A) and tighten it using Allen Key (D).

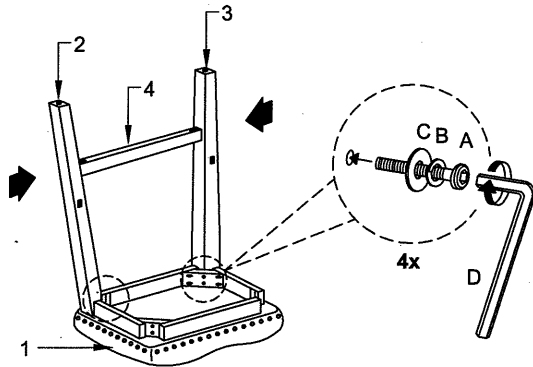

STEP 2

Attached the other Stool Leg (2) to the corner block of Cushion Seat (1). Insert Short Stretcher (5) to the Stool Leg (2) and tight it with Flat Washer (C), Spring Washer (B) and JCBC Bolt (A) and tighten it using Allen Key (D).

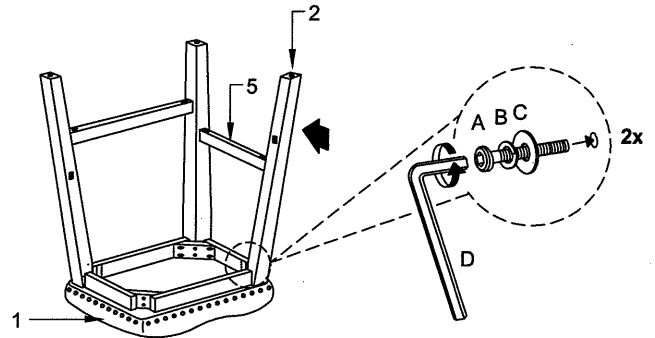

STEP 3

Attached the other Stool Leg (3) to the corner block of Cushion Seat (1). Insert Long Stretcher (4) and Short Stretcher (5) to the Stool Leg (3) and tight it with Flat Washer (C), Spring Washer (B) and JCBC Bolt (A) and tighten it using Allen Key (D). Secure the Short Stretcher (5) and Long Stretcher (4) using CSK Screw (F) and tighten with Phillip Head Screwdriver (not provided).

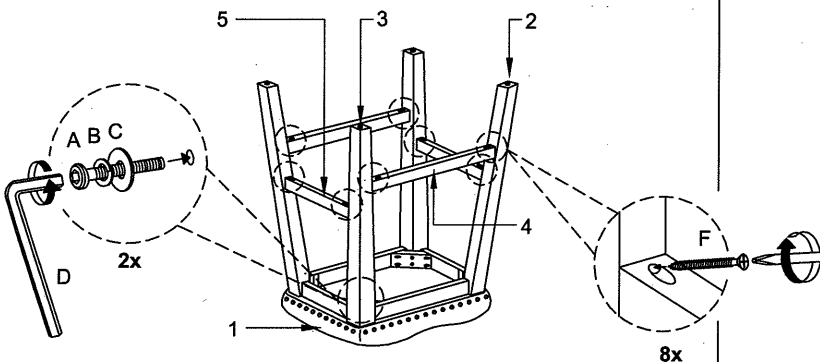

ASSEMBLY COMPLETED

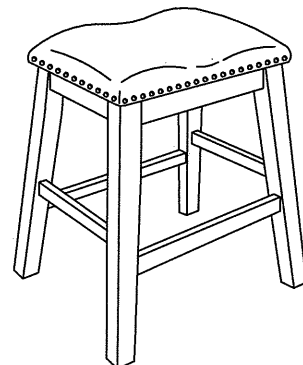

⚠ **NOTE:**
DO NOT TIGHTEN BOLTS UNTIL COMPLETELY ASSEMBLED.
NE PAS SERRER LES BOULONS JUSQU'À CE QUE LE MONTAGE SOIT COMPLETMENT TERMINE